

PedalPCB

Triad Compressor

Revised 4/15/24

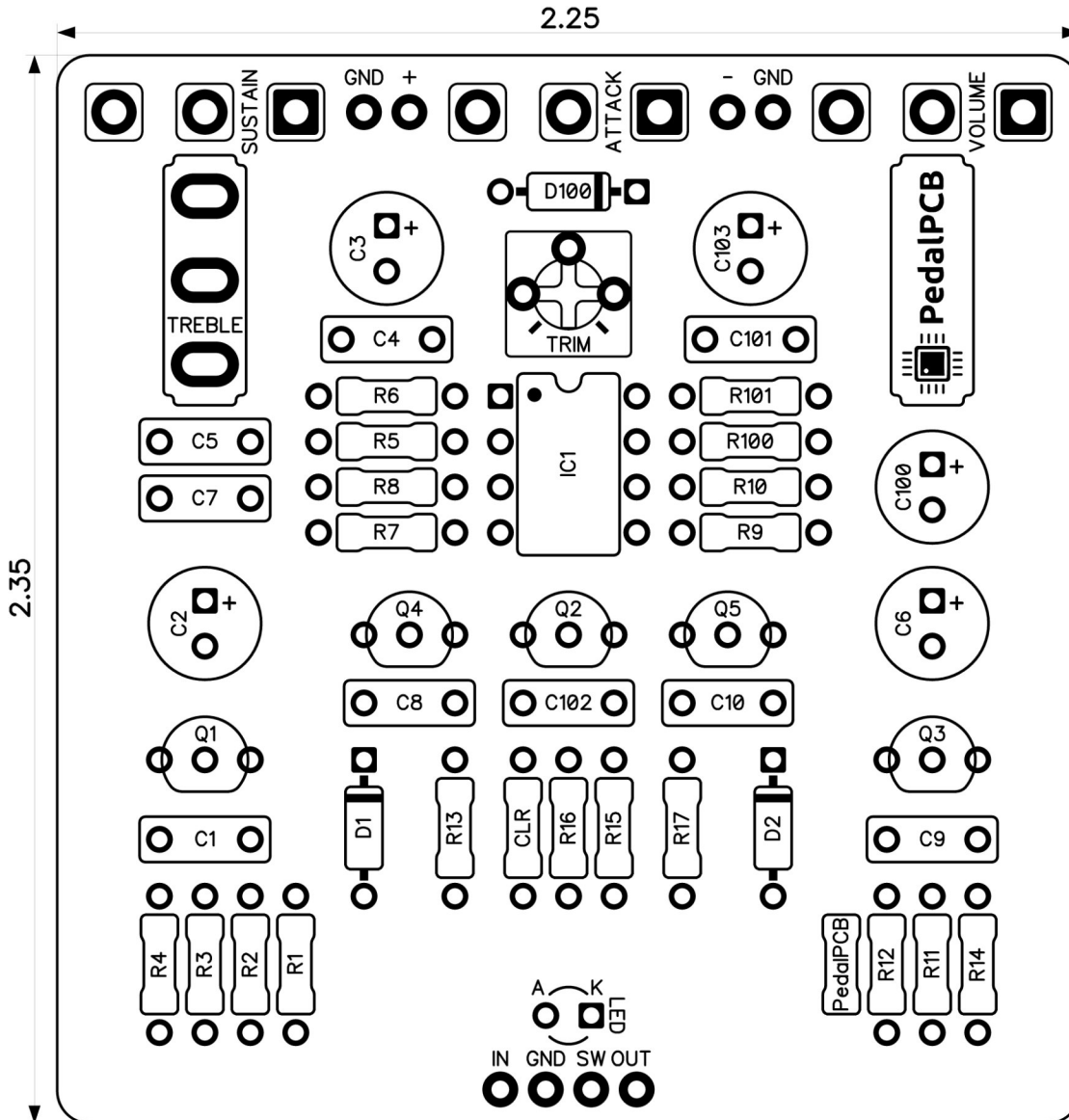

CONTROLS AND FEATURES

- Volume
- Attack
- Sustain
- Treble (Toggle switch)

All trademarks and registered trademarks are the property of their respective owners. The company, product, and service names used in this web site are for identification purposes only. Use of these names, logos, and brands does not imply endorsement.

LOCATION	VALUE	TYPE	NOTES
R1	1M	Resistor, 1/4W	
R2	10K	Resistor, 1/4W	
R3	1M	Resistor, 1/4W	
R4	10K	Resistor, 1/4W	
R5	1M	Resistor, 1/4W	
R6	470K	Resistor, 1/4W	
R7	1M	Resistor, 1/4W	
R8	15K	Resistor, 1/4W	
R9	27K	Resistor, 1/4W	
R10	150K	Resistor, 1/4W	
R11	10K	Resistor, 1/4W	
R12	10K	Resistor, 1/4W	
R13	1M	Resistor, 1/4W	
R14	10K	Resistor, 1/4W	
R15	470K	Resistor, 1/4W	
R16	10K	Resistor, 1/4W	
R17	1M	Resistor, 1/4W	
R100	56K	Resistor, 1/4W	
R101	22K	Resistor, 1/4W	
CLR	4K7	Resistor, 1/4W	* LED current limiting resistor
C1	10n	Film capacitor, 7.2 x 2.5mm	
C2	1u	Electrolytic capacitor, 5mm	
C3	1u	Electrolytic capacitor, 5mm	
C4	10n	Film capacitor, 7.2 x 2.5mm	
C5	1n	Film capacitor, 7.2 x 2.5mm	
C6	10u	Electrolytic capacitor, 5mm	
C7	100p	Ceramic capacitor	
C8	10n	Film capacitor, 7.2 x 2.5mm	
C9	47n	Film capacitor, 7.2 x 2.5mm	
C10	10n	Film capacitor, 7.2 x 2.5mm	
C100	100u	Electrolytic capacitor, 5mm	
C101	100n	Film capacitor, 7.2 x 2.5mm	
C102	100n	Film capacitor, 7.2 x 2.5mm	
C103	10u	Electrolytic capacitor, 5mm	
D1	1N4148	Signal diode, DO-35	
D2	1N4148	Signal diode, DO-35	
D100	1N5817	Schottky diode, DO-41	
Q1	2N3904	BJT transistor, NPN TO-92	
Q2	2N3904	BJT transistor, NPN TO-92	
Q3	2N3904	BJT transistor, NPN TO-92	
Q4	2N3904	BJT transistor, NPN TO-92	
Q5	2N3904	BJT transistor, NPN TO-92	
IC1	LM3080	Operational Transconductance Amplifier	Alternate: AS3080-DIL
TRIM	2K	Trimmer potentiometer, 3362P type	
VOLUME	B50K	16mm right-angle PCB mount pot	
ATTACK	B250K	16mm right-angle PCB mount pot	
SUSTAIN	B500K	16mm right-angle PCB mount pot	
TREBLE	ON/ON	Toggle switch, SPDT	2-position (ON/ON)

Triad Compressor

Schematic Diagram

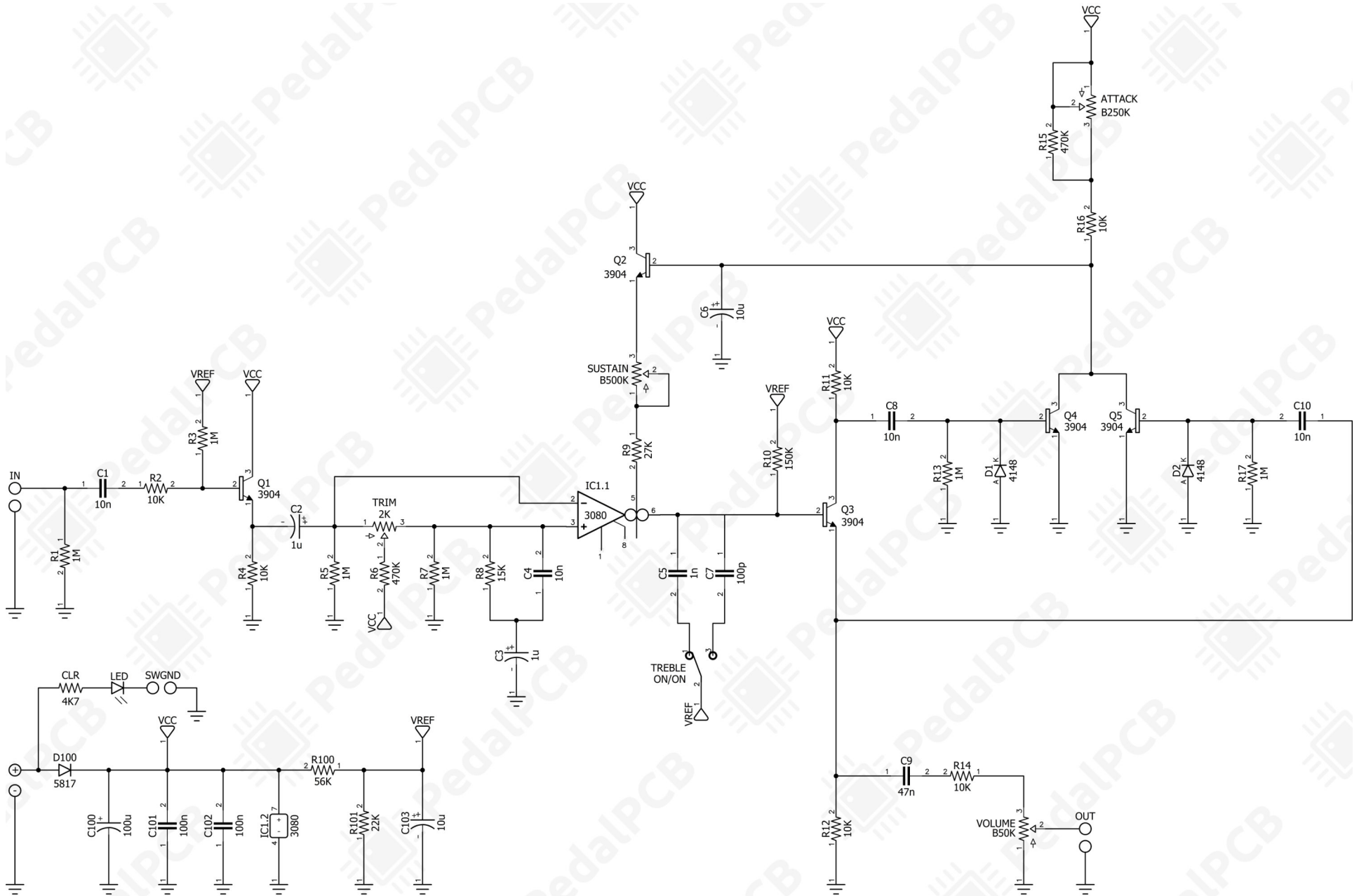

Triad Compressor

Wiring Diagram



Triad Compressor

Drill Template
125B Enclosure

