

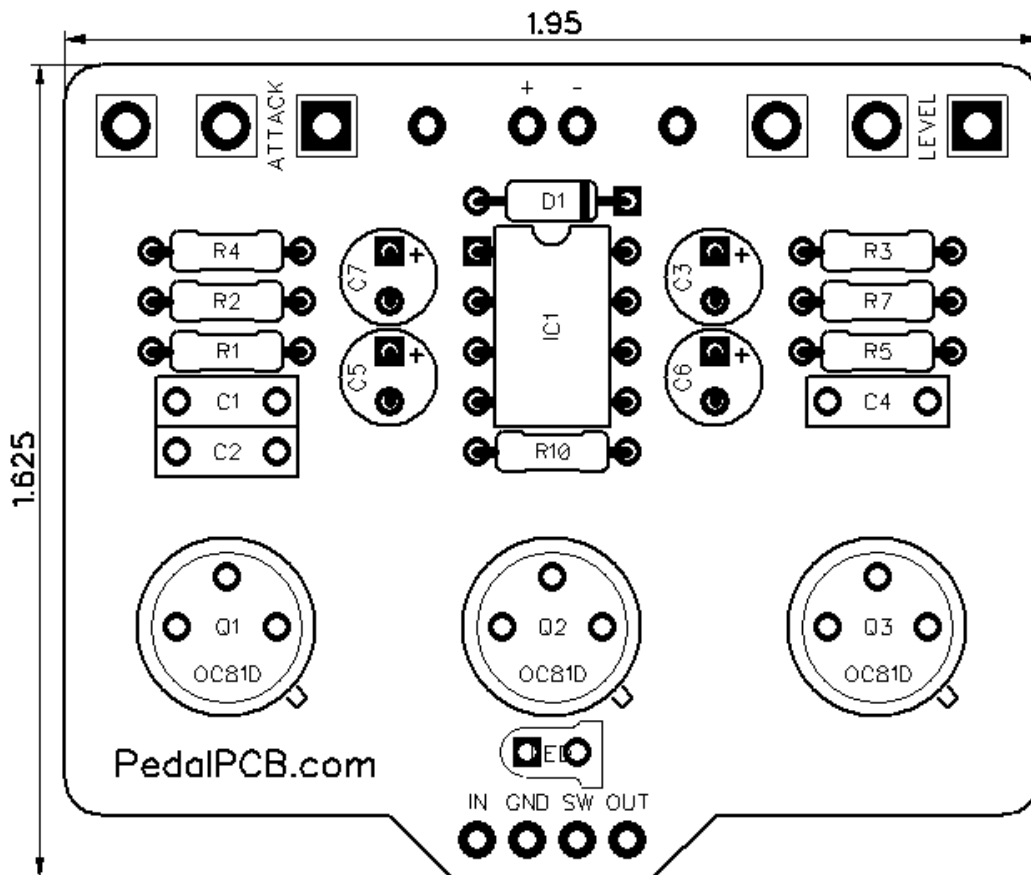

PedalPCB

Tone Vendor MKII

Revision 06.24.18



Controls

- **Volume** - Controls the overall output volume
- **Attack** - Controls the amount of fuzz

All trademarks and registered trademarks are the property of their respective owners. The company, product, and service names used in this web site are for identification purposes only. Use of these names, logos, and brands does not imply endorsement.

Tone Vendor MKII

Parts List

RESISTORS

R1 100K
R2 10K
R3 470
R4 100K
R5 100K
R7 8K2
R10 4K7

CAPACITORS

C1 10n
C2 100n
C3 5u
C4 10n
C5 10u
C6 47u
C7 5u

TRANSISTORS

Q1 OC81D
Q2 OC81D
Q3 OC81D

INTEGRATED CIRCUITS

IC1 TC1044SCPA

DIODES

D1 1N5817

POTENTIOMETERS

ATTACK B1K
LEVEL A100K

Tone Vendor MKII

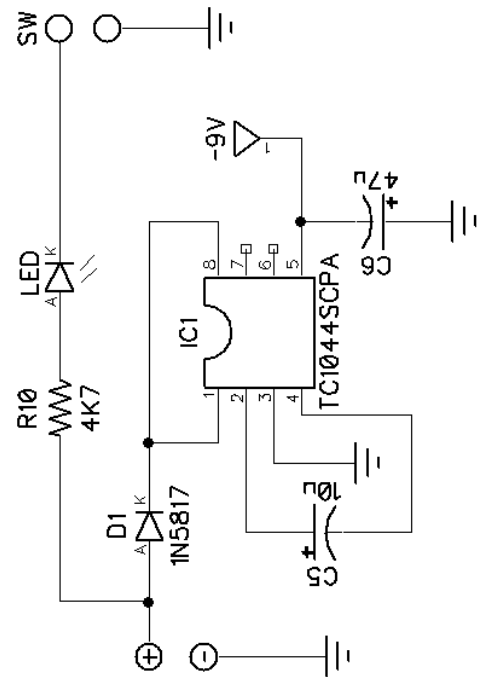
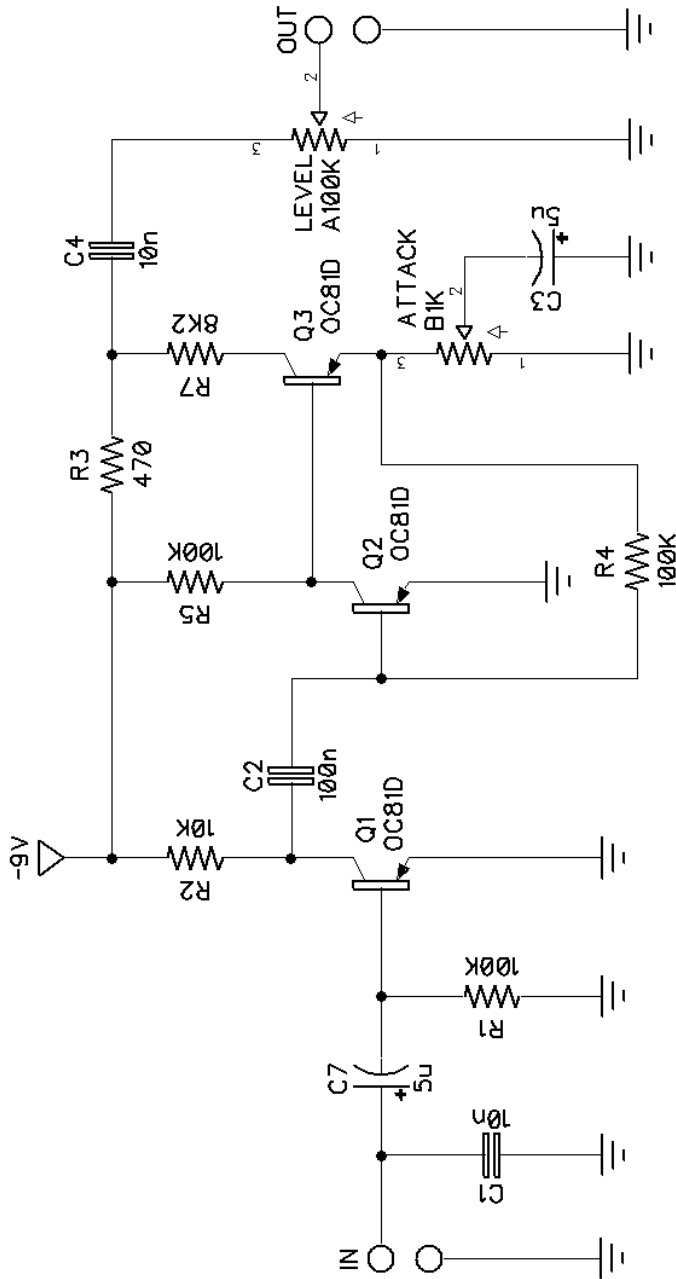

Tone Vendor MKII

Wiring Diagram

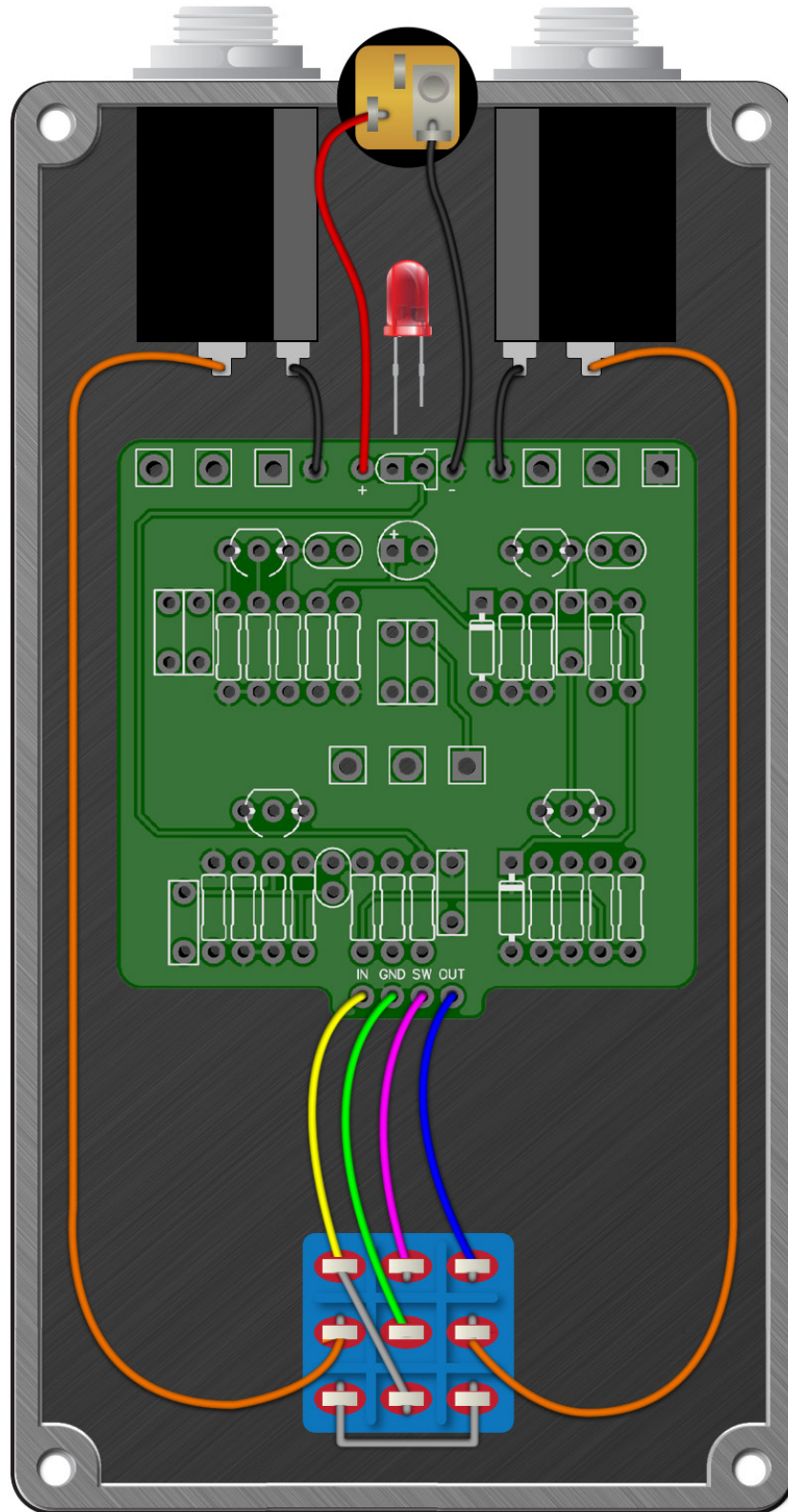

Tone Vendor MKII

Drill Template
125B enclosure with top mounted jacks

