

# PedalPCB

## Speaker Motivator

Revised 5/11/24

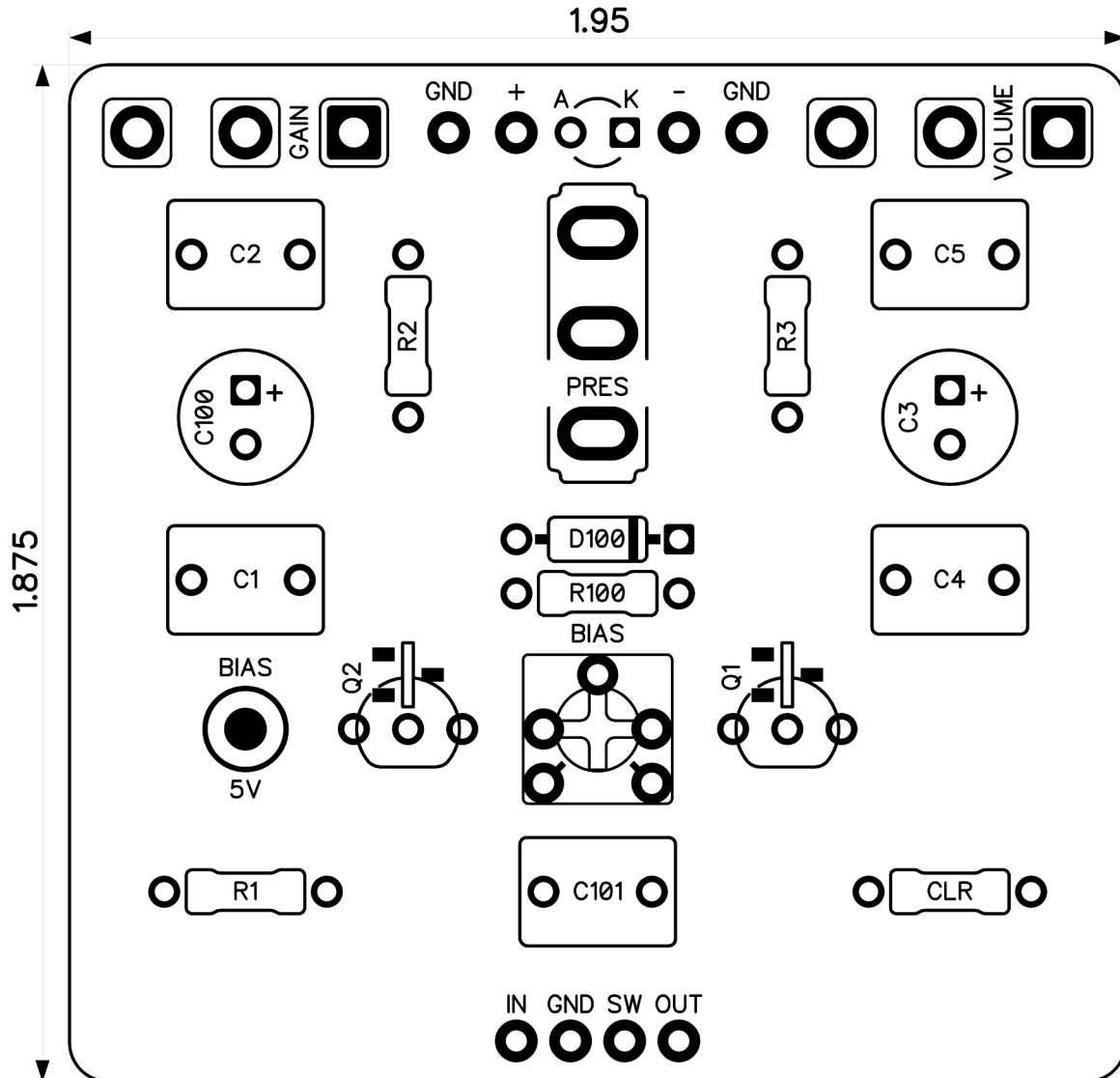

### CONTROLS AND FEATURES

- Volume
- Gain
- Presence (Toggle switch)

All trademarks and registered trademarks are the property of their respective owners. The company, product, and service names used in this web site are for identification purposes only. Use of these names, logos, and brands does not imply endorsement.



# Speaker Motivator

## Schematic Diagram

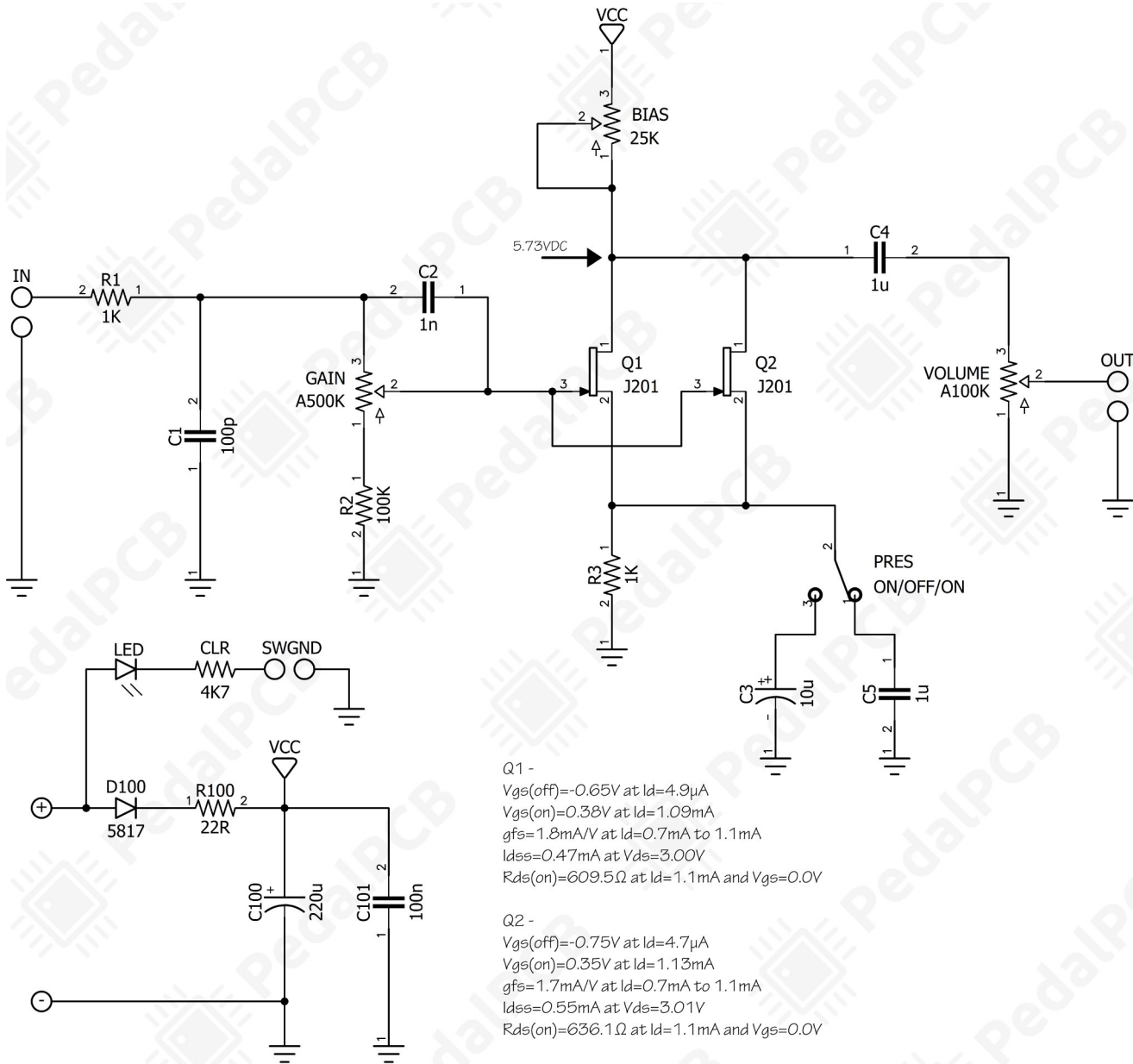

# Speaker Motivator

Wiring Diagram

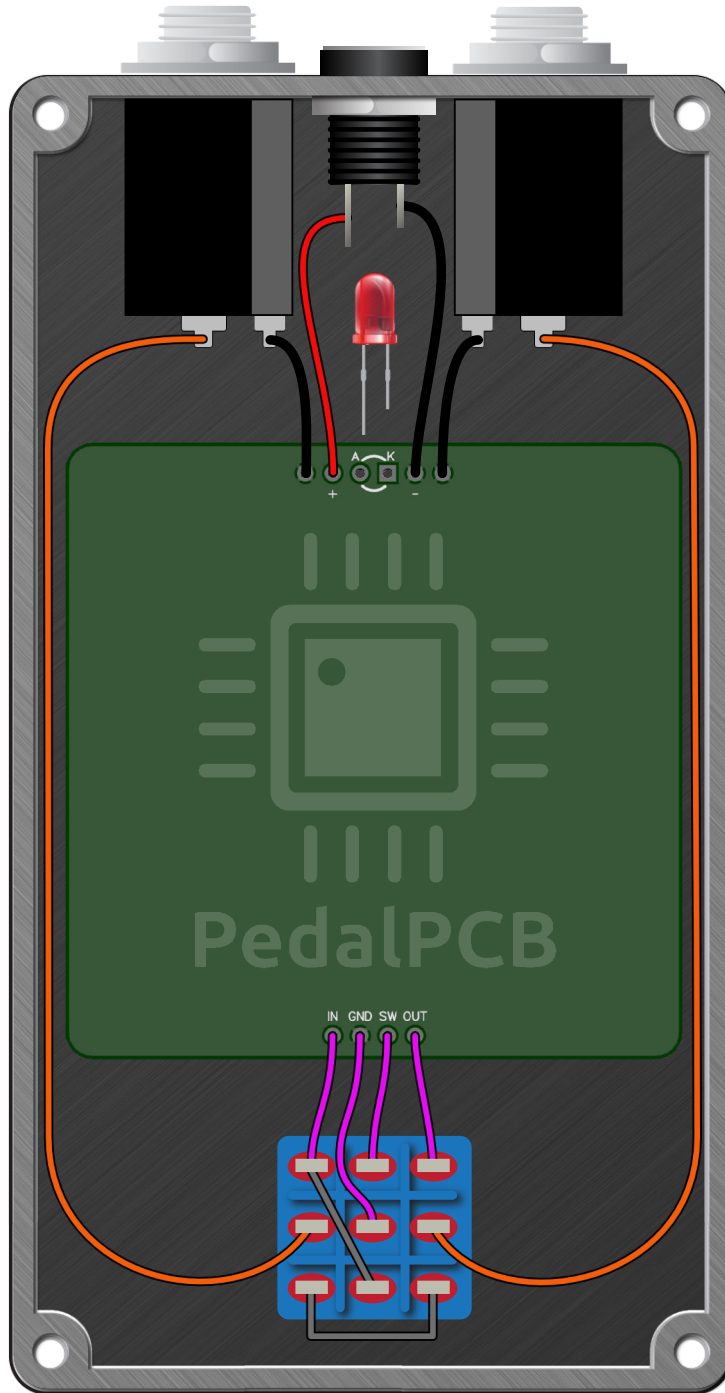

# Speaker Motivator

Drill Template  
125B Enclosure

