

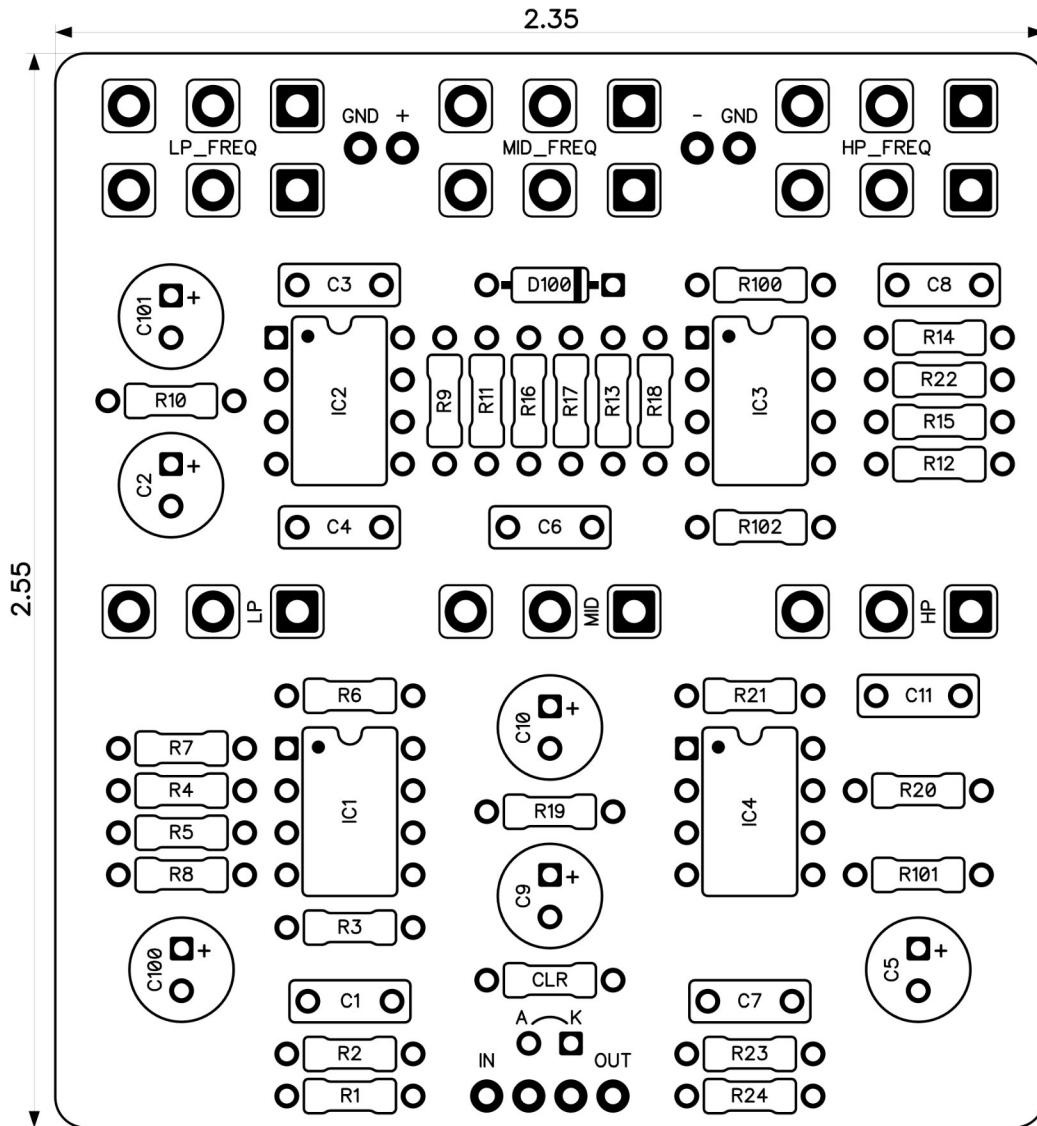

Referee EQ

Revised 4/29/26



CONTROLS AND FEATURES

- High Pass Frequency
- Mid Frequency
- Low Pass Frequency
-
- Hi Pass Resonance
- Mid Resonance
- Low Pass Resonance

All trademarks and registered trademarks are the property of their respective owners. The company, product, and service names used in this web site are for identification purposes only. Use of these names, logos, and brands does not imply endorsement.

LOCATION	VALUE	TYPE	NOTES
R1	1K	Resistor, 1/4W	
R2	2M	Resistor, 1/4W	
R3	2M	Resistor, 1/4W	
R4	10K	Resistor, 1/4W	
R5	470R	Resistor, 1/4W	
R6	10K	Resistor, 1/4W	
R7	15K	Resistor, 1/4W	
R8	10K	Resistor, 1/4W	
R9	10K	Resistor, 1/4W	
R10	15K	Resistor, 1/4W	
R11	10K	Resistor, 1/4W	
R12	470R	Resistor, 1/4W	
R13	10K	Resistor, 1/4W	
R14	15K	Resistor, 1/4W	
R15	10K	Resistor, 1/4W	
R16	12K	Resistor, 1/4W	
R17	12K	Resistor, 1/4W	
R18	2K7	Resistor, 1/4W	
R19	5K6	Resistor, 1/4W	
R20	10K	Resistor, 1/4W	
R21	2K7	Resistor, 1/4W	
R22	15K	Resistor, 1/4W	
R23	100K	Resistor, 1/4W	
R24	100R	Resistor, 1/4W	
R100	47R	Resistor, 1/4W	
R101	10K	Resistor, 1/4W	
R102	10K	Resistor, 1/4W	
CLR	4K7	Resistor, 1/4W	* LED current limiting resistor
C1	100n	Film capacitor, 7.2 x 2.5mm	
C2	100u	Electrolytic capacitor, 5mm	
C3	4n7	Film capacitor, 7.2 x 2.5mm	
C4	4n7	Film capacitor, 7.2 x 2.5mm	
C5	100u	Electrolytic capacitor, 5mm	
C6	6n8	Film capacitor, 7.2 x 2.5mm	
C7	6n8	Film capacitor, 7.2 x 2.5mm	
C8	56n	Film capacitor, 7.2 x 2.5mm	
C9	10u	Electrolytic capacitor, 5mm	
C10	1u	Electrolytic capacitor, 5mm	
C11	56n	Film capacitor, 7.2 x 2.5mm	
C100	100u	Electrolytic capacitor, 5mm	
C101	100u	Electrolytic capacitor, 5mm	
D100	1N5817	Schottky diode, DO-41	
IC1	TL072	Dual op-amp, DIP8	
IC2	TL072	Dual op-amp, DIP8	
IC3	TL072	Dual op-amp, DIP8	
IC4	TL072	Dual op-amp, DIP8	
HP_FREQ	A100K DUAL	16mm right-angle PCB mount pot	*Dual gang potentiometer
MID_FREQ	A100K DUAL	16mm right-angle PCB mount pot	*Dual gang potentiometer
LP_FREQ	A100K DUAL	16mm right-angle PCB mount pot	*Dual gang potentiometer
HP	C10K	16mm right-angle PCB mount pot	
MID	B10K	16mm right-angle PCB mount pot	
LP	C10K	16mm right-angle PCB mount pot	

