

PedalPCB

Recycler Overdrive

Revised 10/28/22

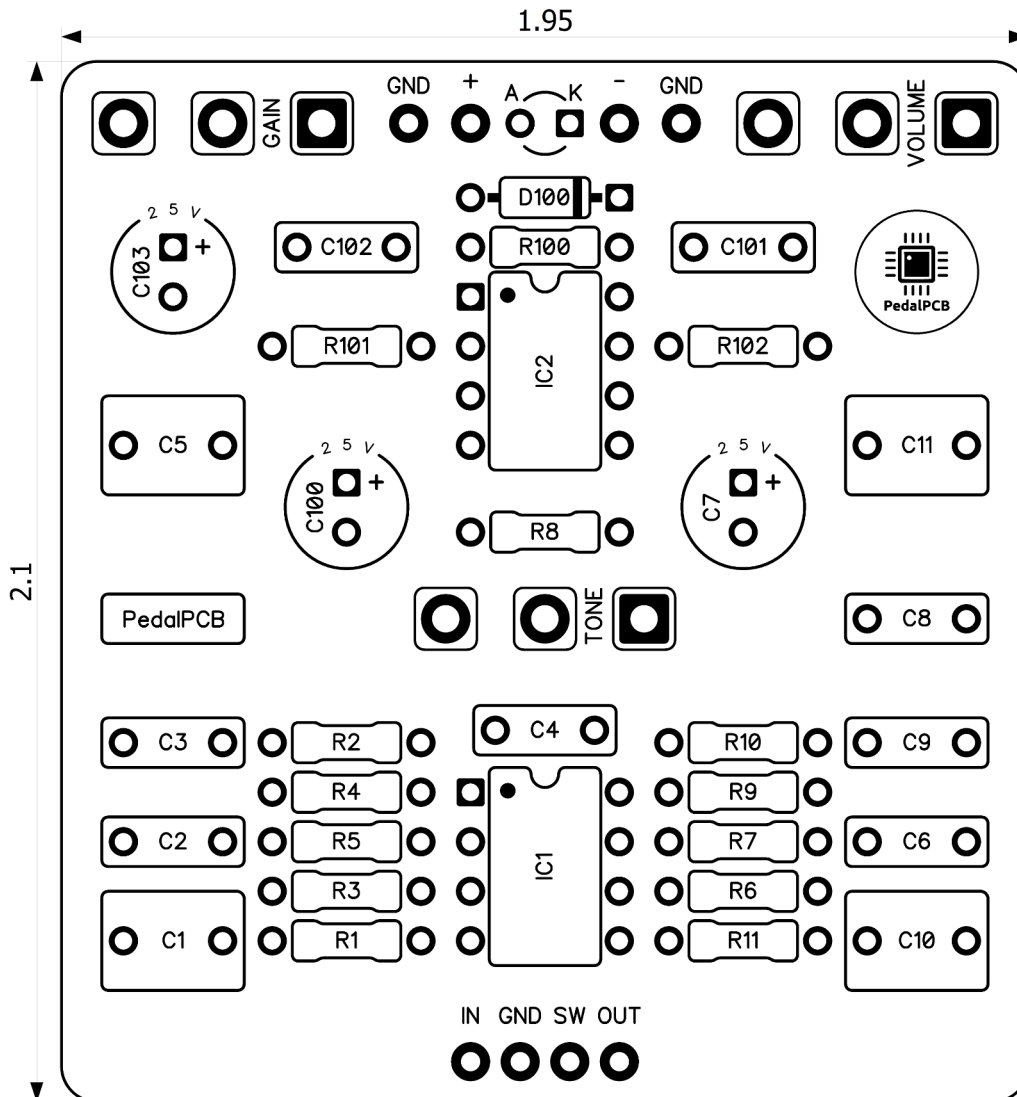

CONTROLS AND FEATURES

- Volume
- Tone
- Gain

All trademarks and registered trademarks are the property of their respective owners. The company, product, and service names used in this web site are for identification purposes only. Use of these names, logos, and brands does not imply endorsement.

Recycler Overdrive

Schematic Diagram

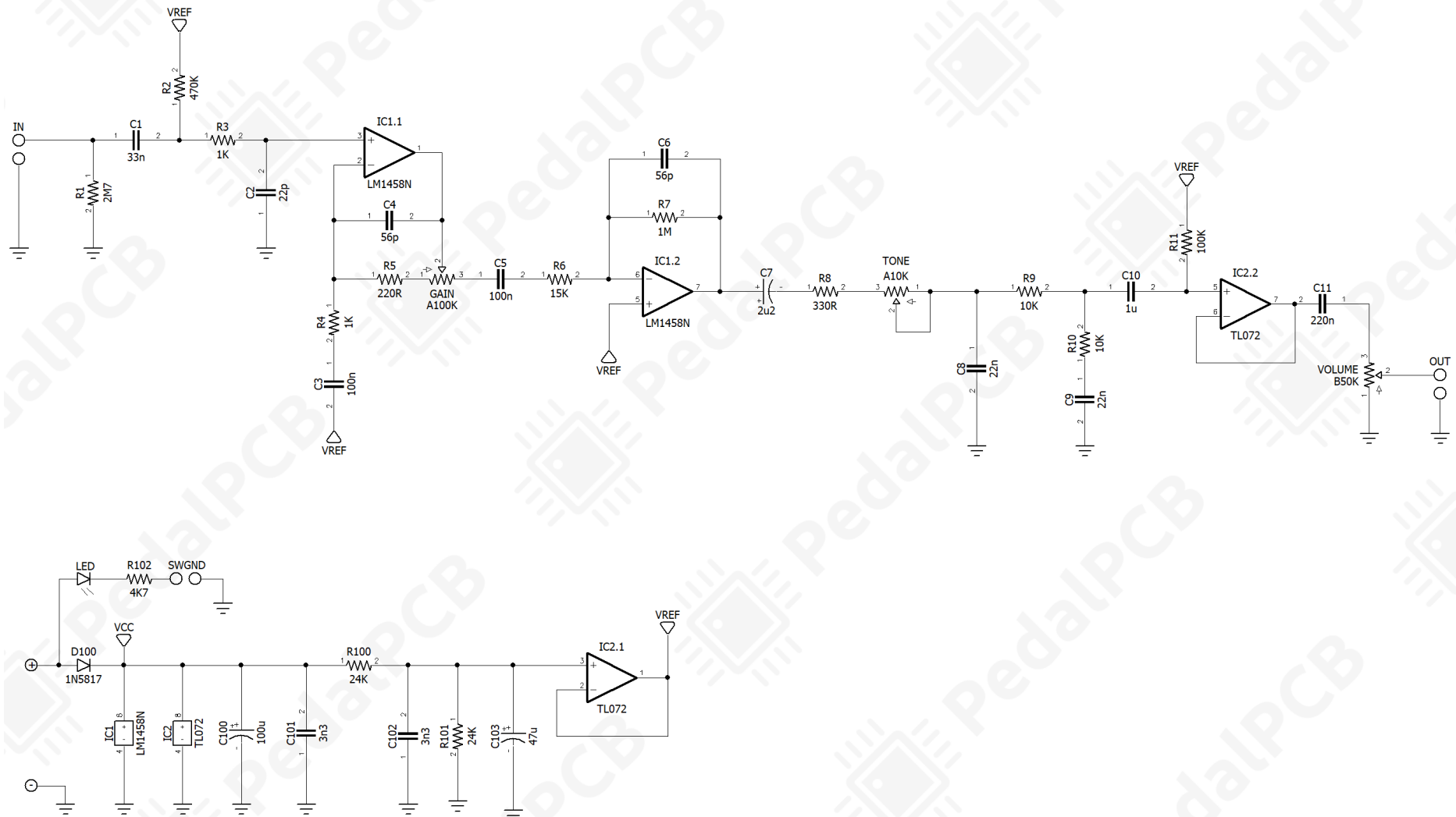

Recycler Overdrive

Wiring Diagram

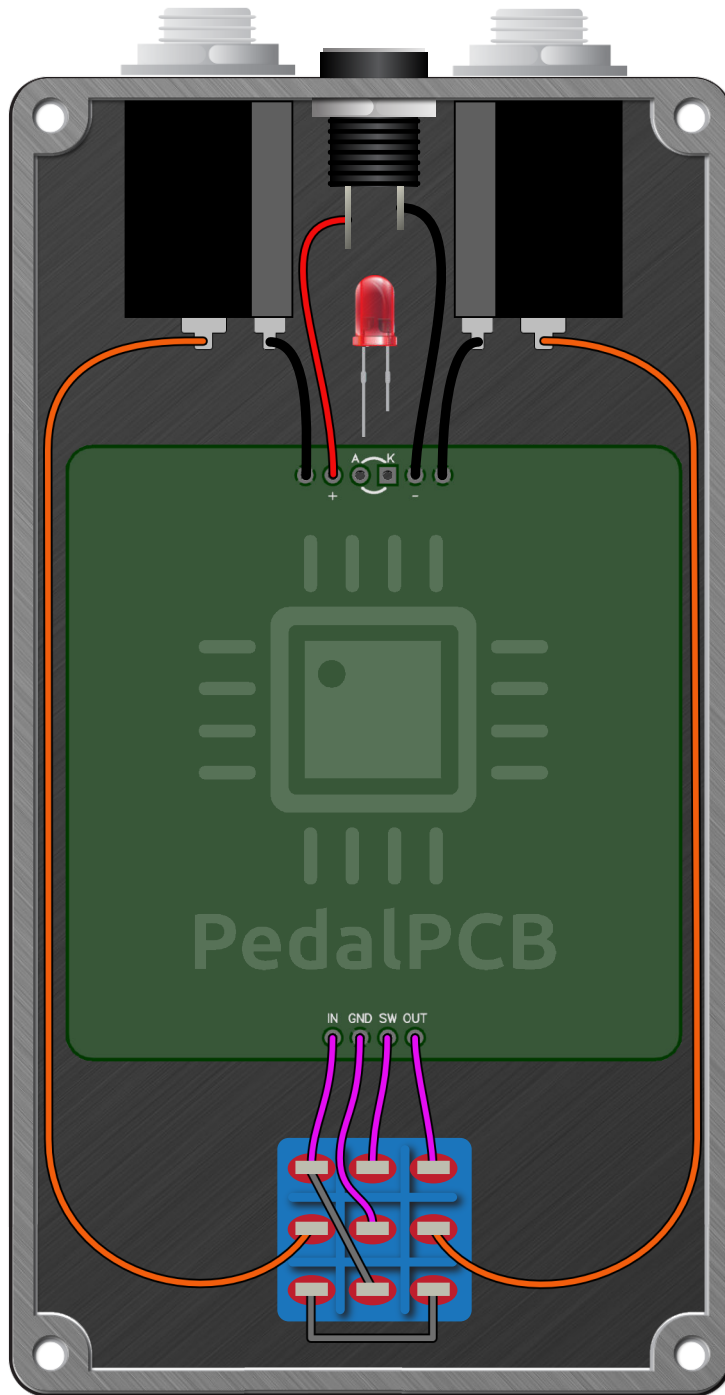

Recycler Overdrive

Drill Template
125B Enclosure

