

PedalPCB

Powersound Boost

Revised 8/15/23

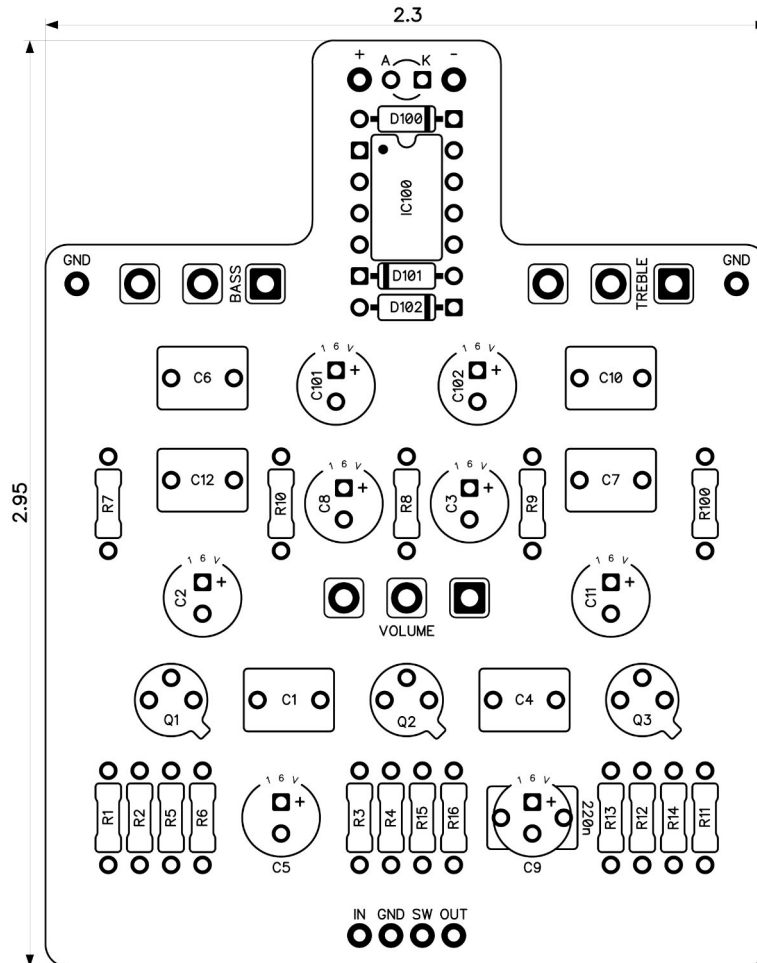

CONTROLS AND FEATURES

- Treble
- Bass
- Volume

All trademarks and registered trademarks are the property of their respective owners. The company, product, and service names used in this web site are for identification purposes only. Use of these names, logos, and brands does not imply endorsement.

LOCATION	VALUE	TYPE	NOTES
R1	4K7	Resistor, 1/4W	
R2	120K	Resistor, 1/4W	
R3	1K8	Resistor, 1/4W	
R4	1K2	Resistor, 1/4W	
R5	150K	Resistor, 1/4W	
R6	12K	Resistor, 1/4W	
R7	4K7	Resistor, 1/4W	
R8	39K	Resistor, 1/4W	
R9	5K6	Resistor, 1/4W	
R10	4K7	Resistor, 1/4W	
R11	33K	Resistor, 1/4W	
R12	180K	Resistor, 1/4W	
R13	1K8	Resistor, 1/4W	
R14	1K	Resistor, 1/4W	
R15	470R	Resistor, 1/4W	
R16	10K	Resistor, 1/4W	
R100	4K7	Resistor, 1/4W	* LED current limiting resistor
C1	220n	Film capacitor, 7.2 x 5.0mm	
C2	22u	Electrolytic capacitor, 5mm	
C3	22u	Electrolytic capacitor, 5mm	
C4	220p	Ceramic capacitor	
C5	4u7	Electrolytic capacitor, 5mm	
C6	10n	Film capacitor, 7.2 x 2.5mm	
C7	100n	Film capacitor, 7.2 x 2.5mm	
C8	22u	Electrolytic capacitor, 5mm	
C9	4u7	Electrolytic capacitor, 5mm	
C10	10n	Film capacitor, 7.2 x 2.5mm	
C11	4u7	Electrolytic capacitor, 5mm	
C12	100n	Film capacitor, 7.2 x 2.5mm	
C13	220n	Film capacitor, 7.2 x 5.0mm	
C101	10u	Electrolytic capacitor, 5mm	
C102	22u	Electrolytic capacitor, 5mm	
D100	1N5817	Schottky diode, DO-41	
D101	1N5817	Schottky diode, DO-41	
D102	1N5817	Schottky diode, DO-41	
IC100	TC1044SCPA	Charge pump IC, DIP8	
Q1	BC109	BJT transistor, NPN TO-18	
Q2	BC109	BJT transistor, NPN TO-18	
Q3	BC109	BJT transistor, NPN TO-18	
TREBLE	B100K	16mm right-angle PCB mount pot	
BASS	B100K	16mm right-angle PCB mount pot	
VOLUME	B10K	16mm right-angle PCB mount pot	

Powersound Boost

Schematic Diagram

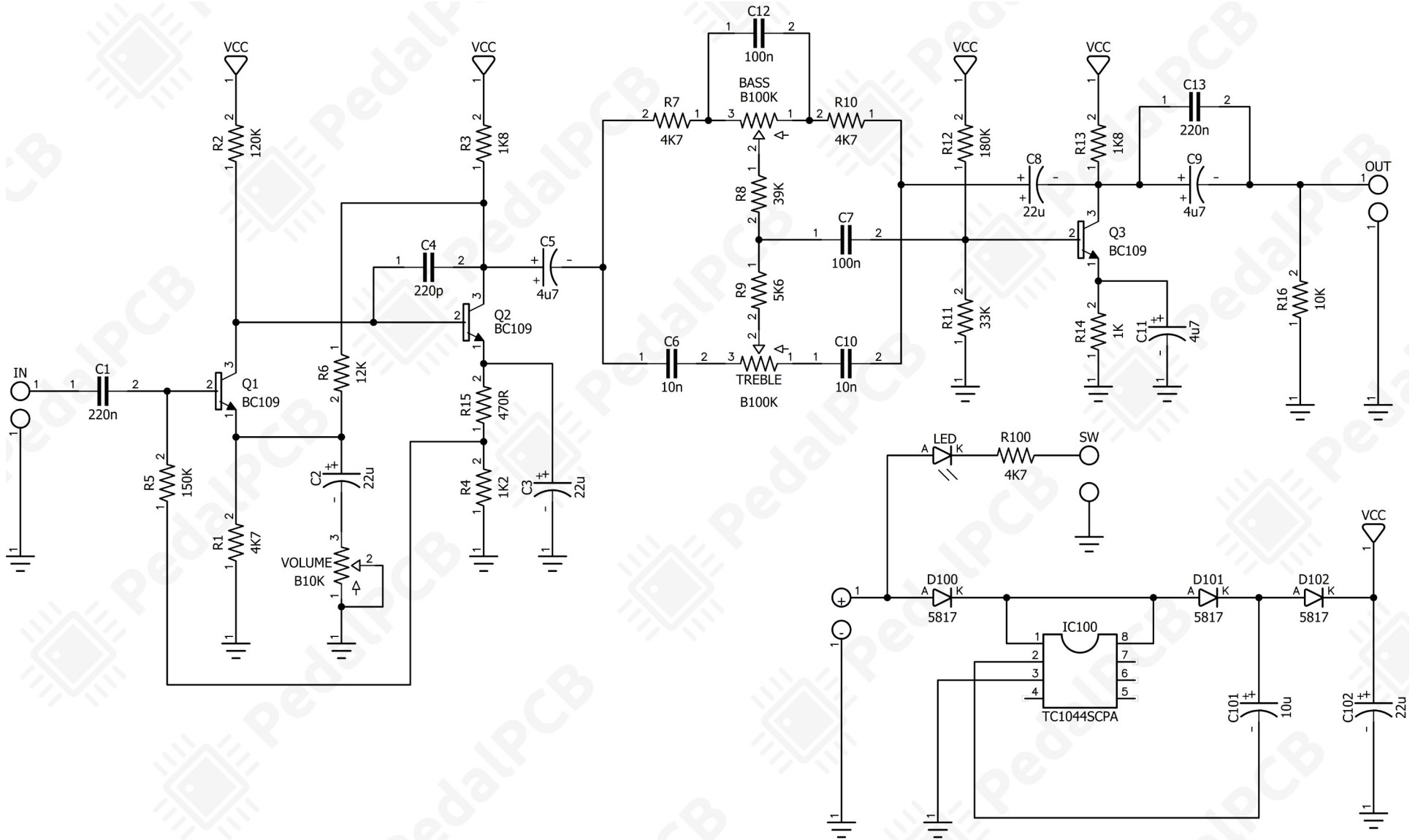



Powersound Boost

Drill Template
125B Enclosure

