

PedalPCB

Lot Lizard Octave Fuzz

Revised 4/26/23

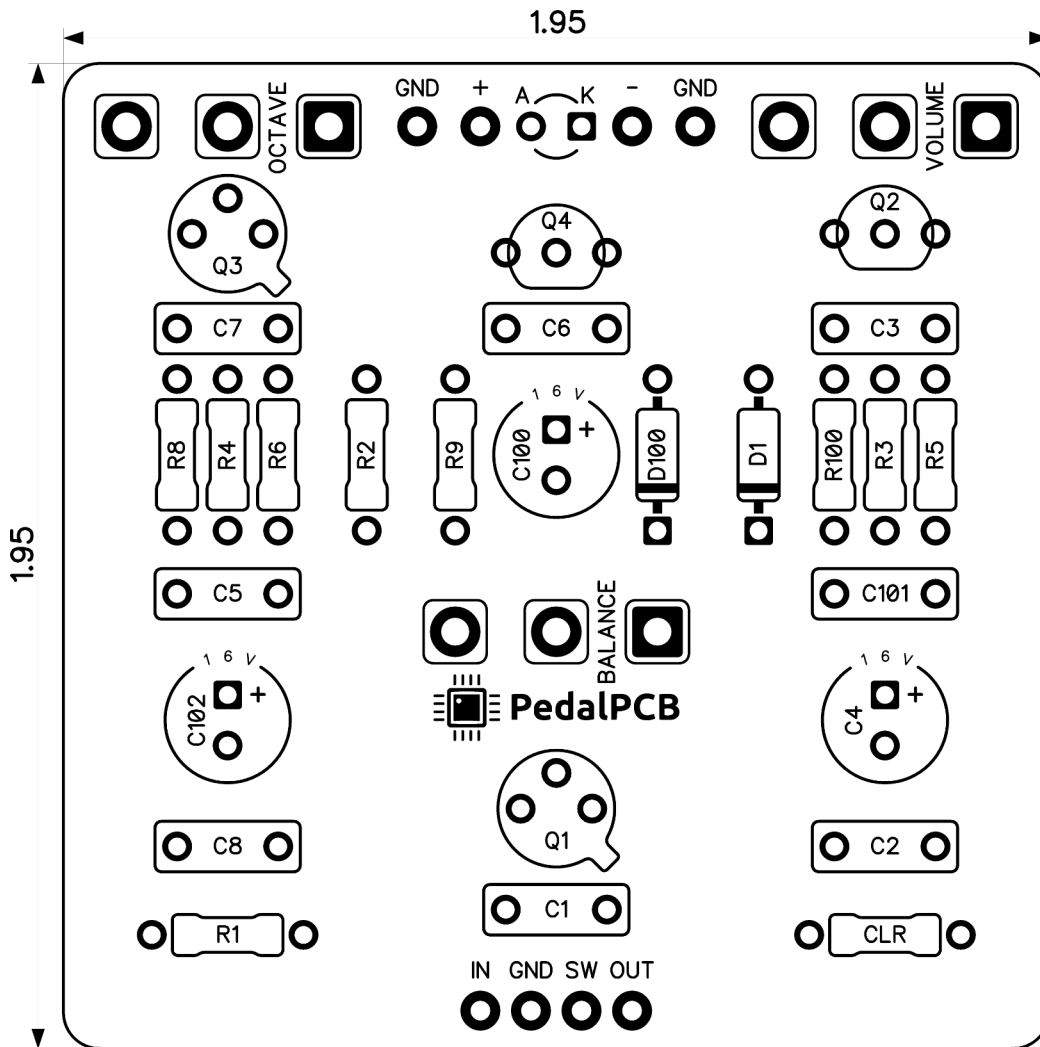

CONTROLS AND FEATURES

- Volume
- Balance
- Octave

All trademarks and registered trademarks are the property of their respective owners. The company, product, and service names used in this web site are for identification purposes only. Use of these names, logos, and brands does not imply endorsement.

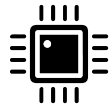

Lot Lizard Octave Fuzz

Schematic Diagram

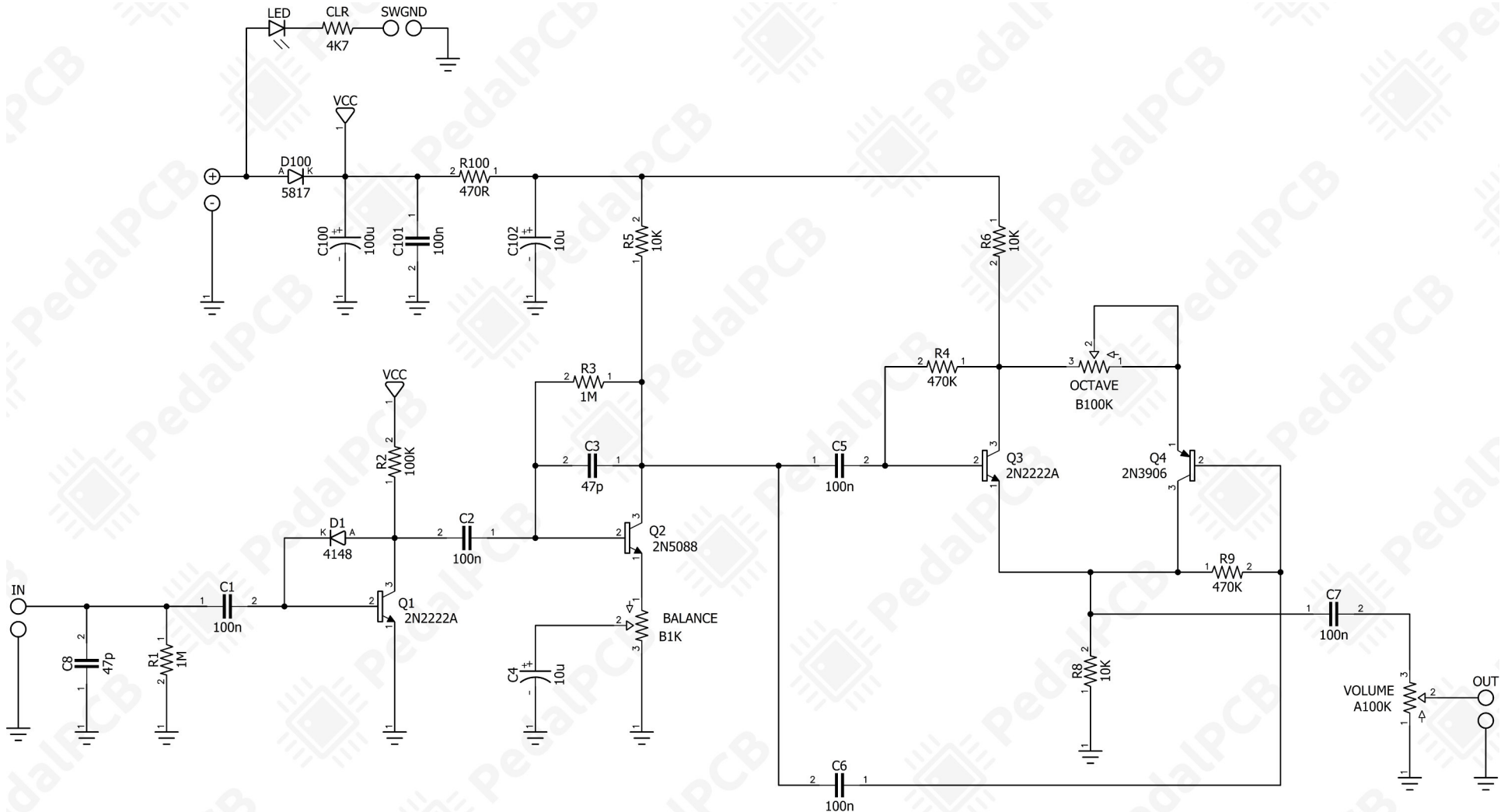

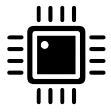

Lot Lizard Octave Fuzz

Wiring Diagram

