

PedalPCB

Ionizer 2

Revision 06.23.18

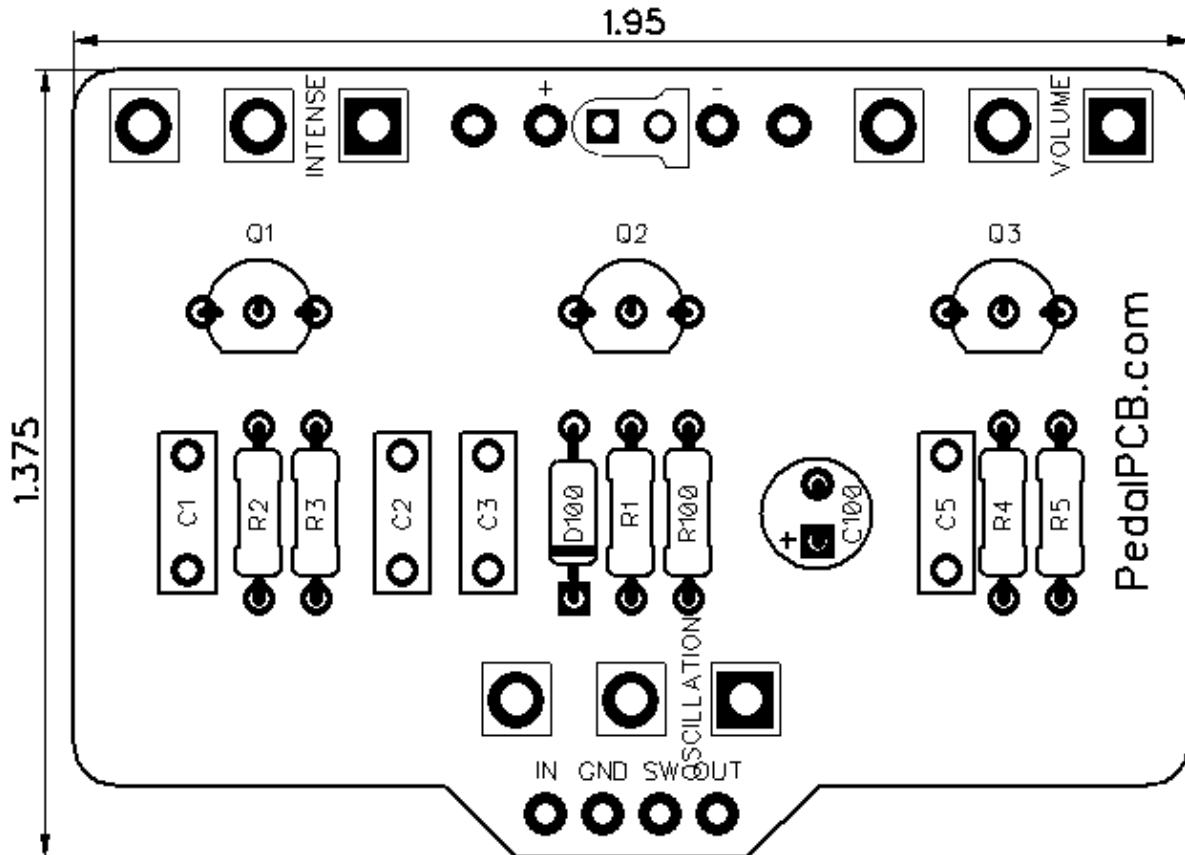

Controls

- **Volume** - Controls the overall output volume
- **Intensity** - Controls the level of fuzz
- **Oscillation** - Controls the amount of voltage/current starve

All trademarks and registered trademarks are the property of their respective owners. The company, product, and service names used in this web site are for identification purposes only. Use of these names, logos, and brands does not imply endorsement.

Ionizer 2

Parts List

RESISTORS

R1 1K
R2 2M2
R3 10K
R4 2M2
R5 10K
R100 4K7

CAPACITORS

C1 100n
C2 100n
C3 100n
C5 100n
C100 47u

TRANSISTORS

Q1 MPSA18
Q2 MPSA18
Q3 2N2907A

DIODES

D100 1N5817

POTENTIOMETERS

VOLUME B100K
INTENSE B100K
OSCILLATION B100K



Ionizer 2

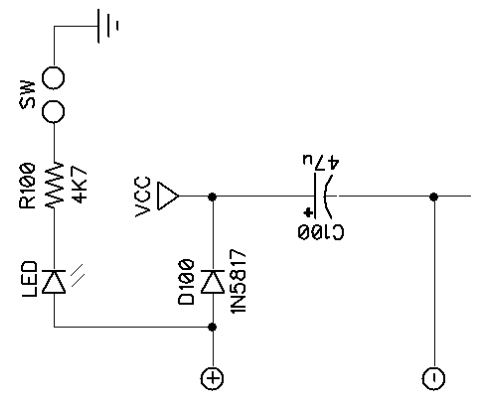
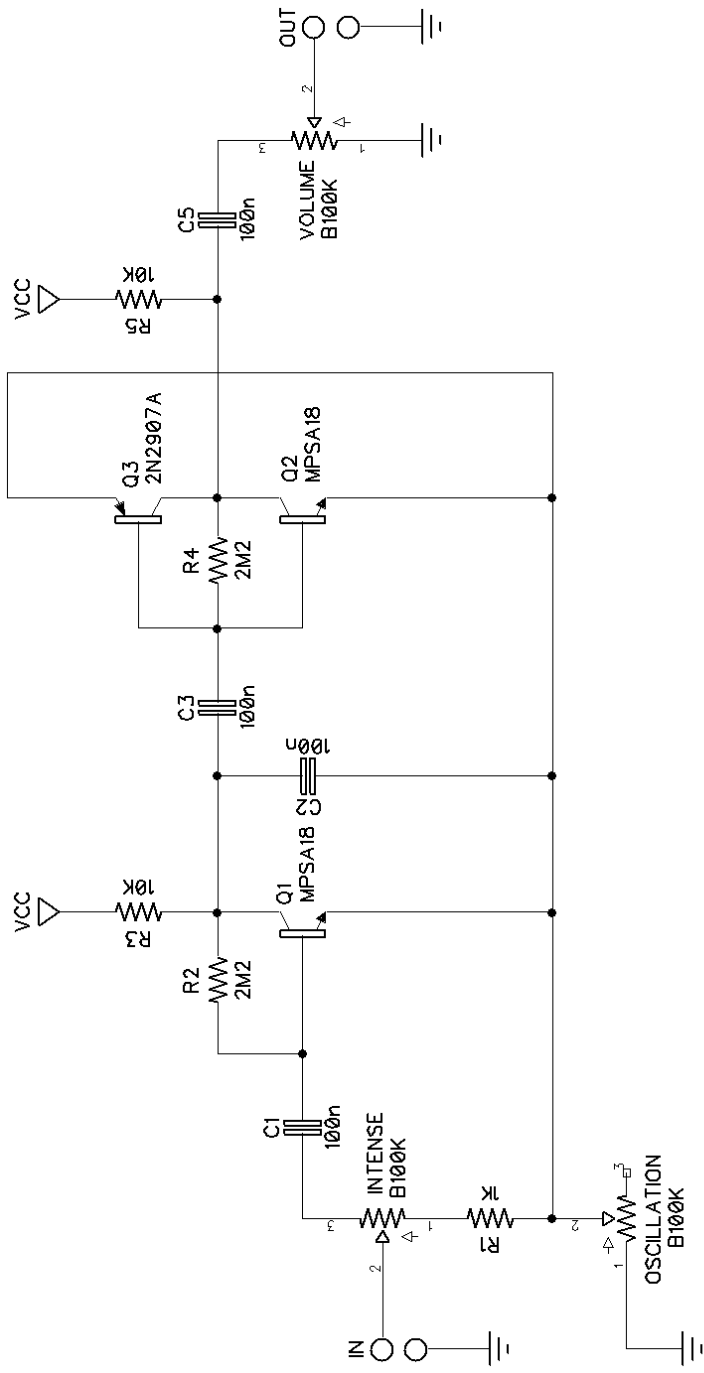

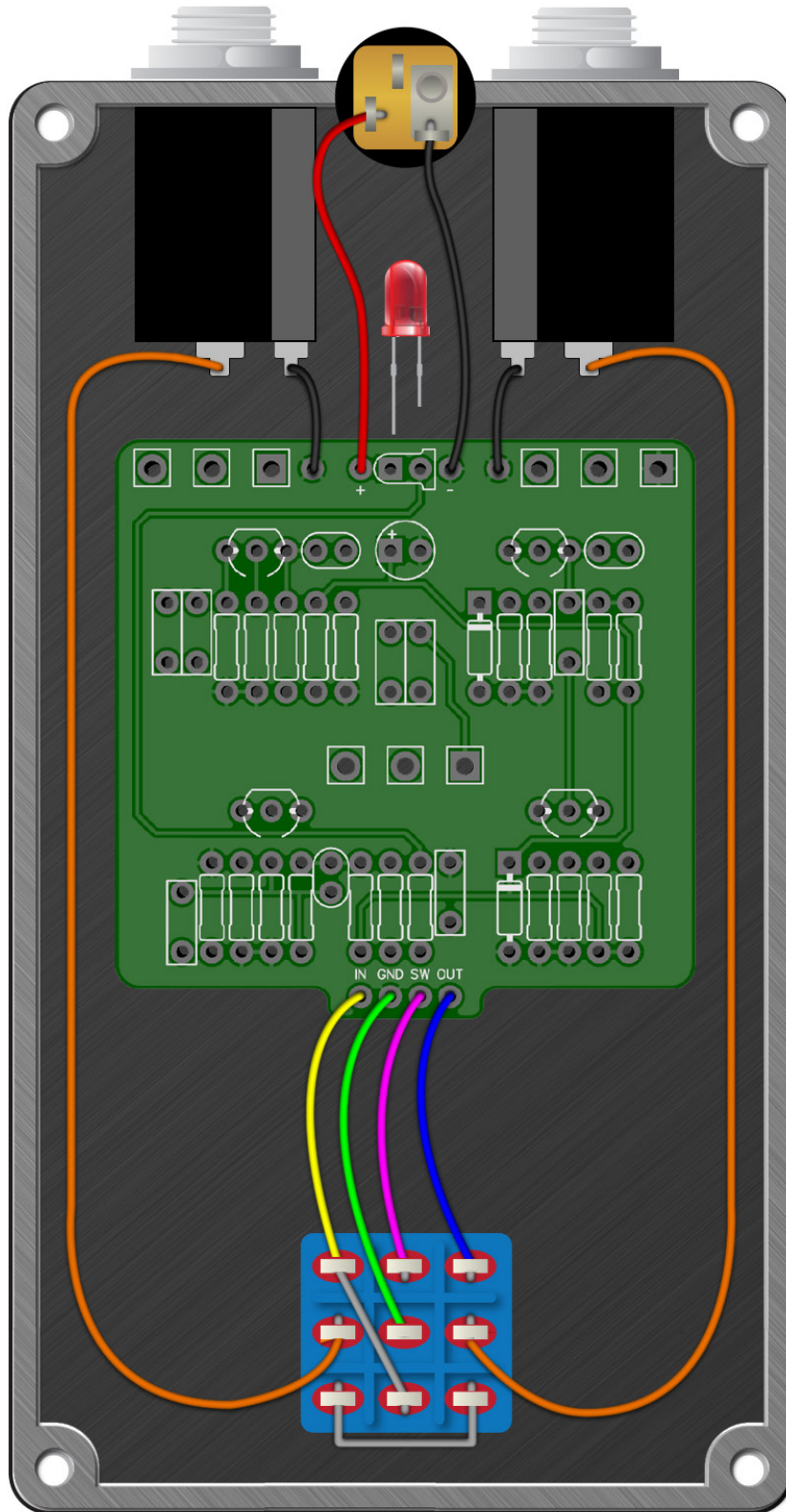

Ionizer 2

Drill Template
125B enclosure with top mounted jacks

