

PedalPCB

Enchanted Boost

Revised 10/11/23

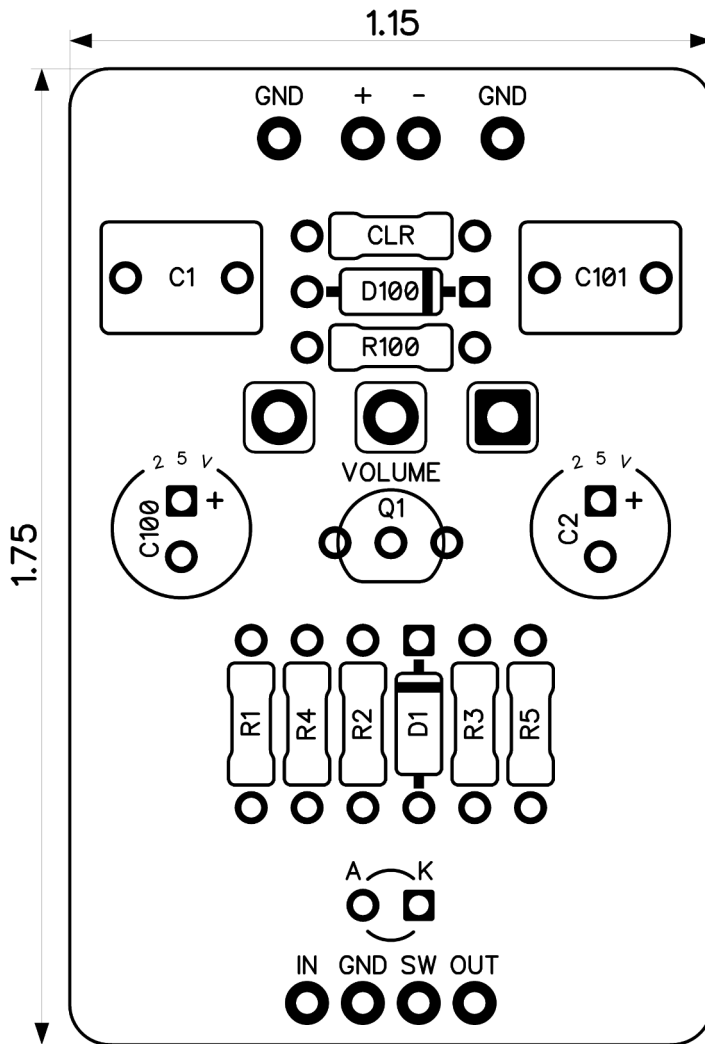

CONTROLS AND FEATURES

- Volume

All trademarks and registered trademarks are the property of their respective owners. The company, product, and service names used in this web site are for identification purposes only. Use of these names, logos, and brands does not imply endorsement.

Enchanted Boost

Schematic Diagram

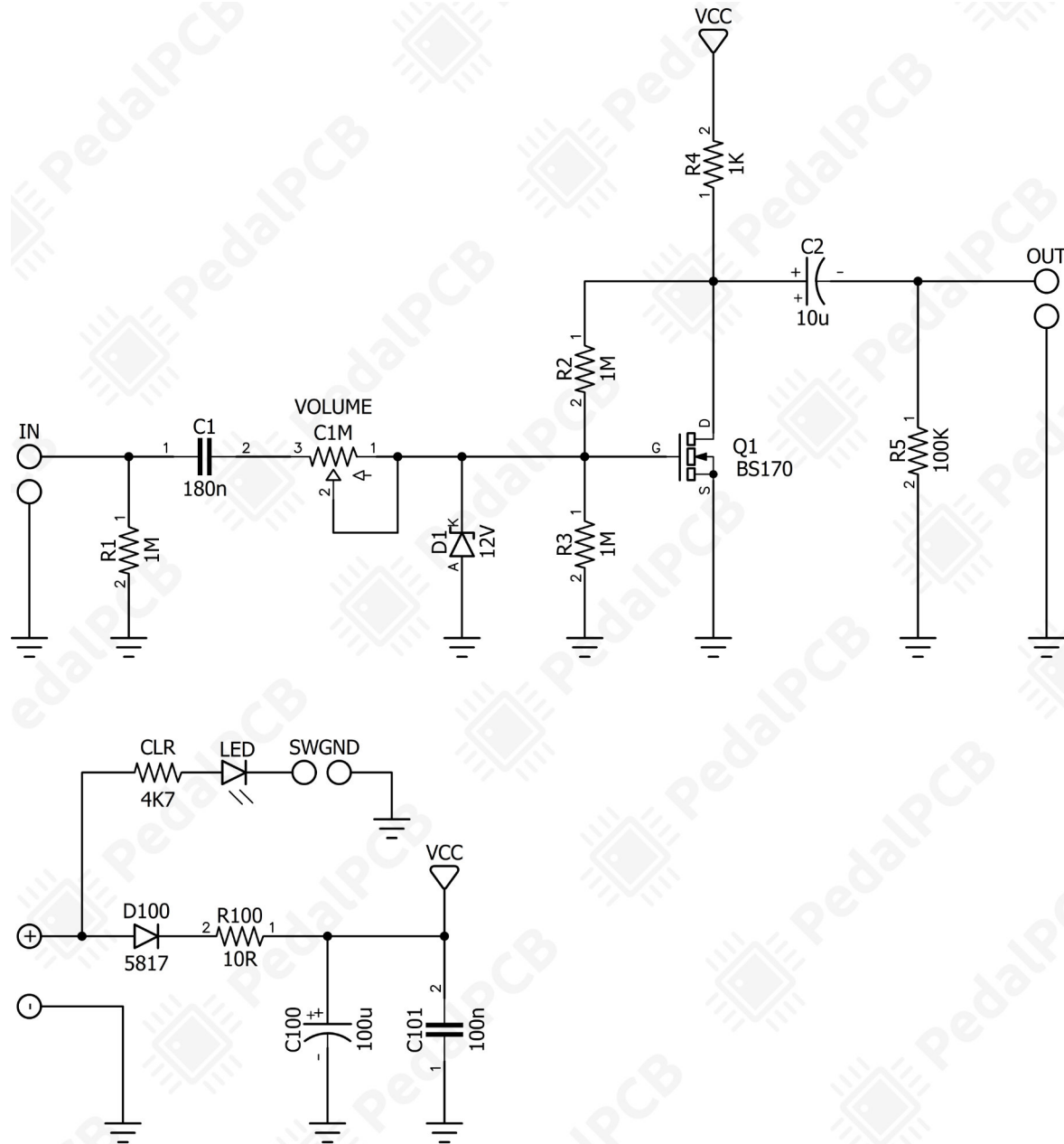

Enchanted Boost

Wiring Diagram

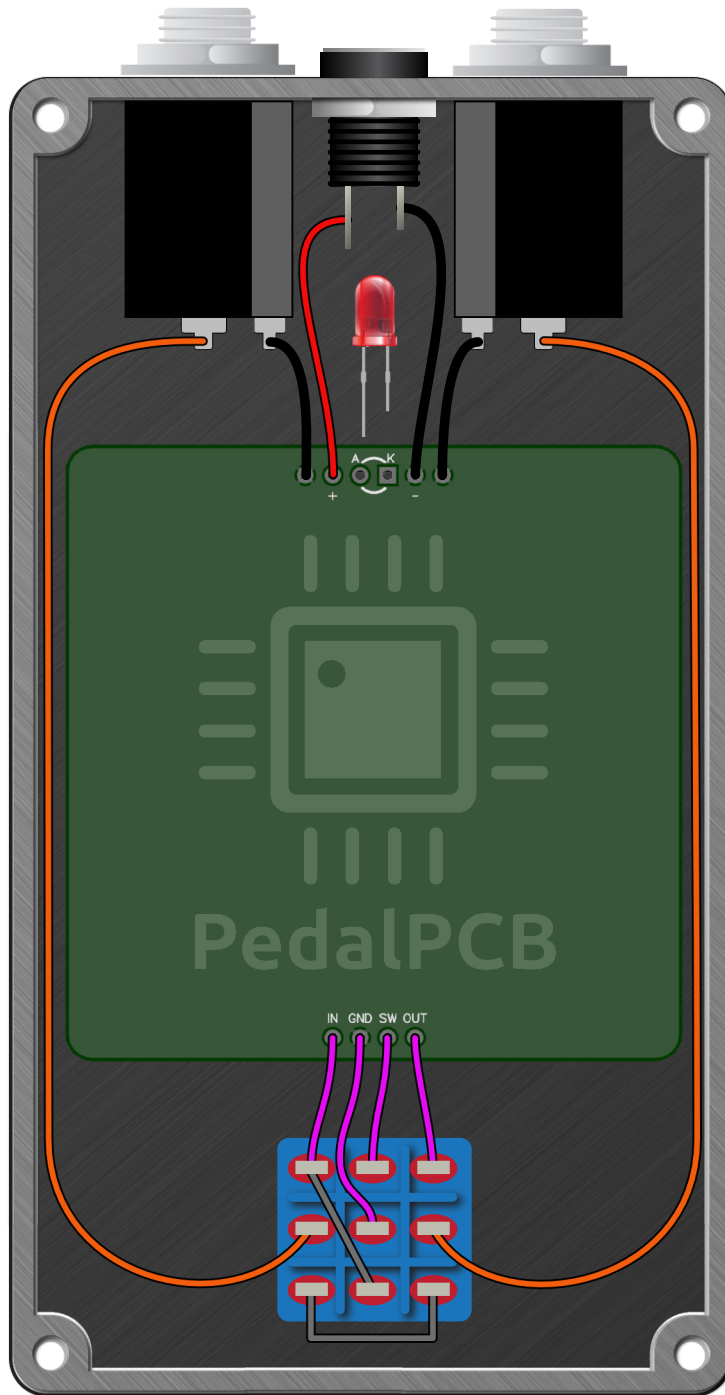

Enchanted Boost

Drill Template
125B Enclosure

